

IPE-205: **M**ANUFACTURING **P**ROCESSES-I

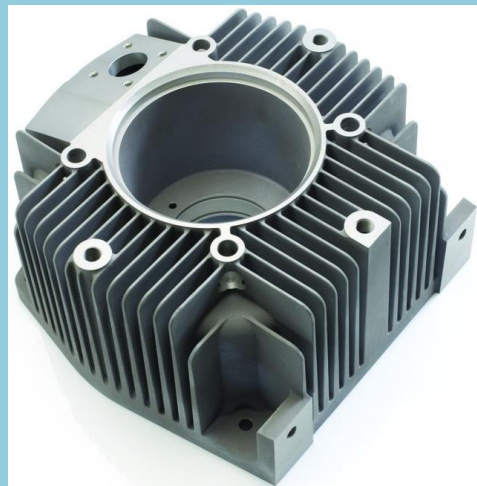

DR. NIKHIL R. DHAR

Professor, IPE Department
BUET

Course Outlines

- Metal Casting Processes [1½ Questions]: Introduction, Sand casting procedures, Pattern making, Material types and construction of patterns, Pattern allowances, Molding sand, Molding sand properties, Molding process, Molding materials, Casting processes, Sand casting defects etc.
- Bulk Deformation Processes in Metalworking [1½ Questions]: Rolling, Forging and Extrusion and Other deformation processes related to forging.
- Sheet Metal Working [2 Questions]: Cutting operations, bending operations, drawing, Other sheet metal forming operations, precision forming processes; various features of different types of metal forming dies; principles of powder forming.
- Metal Joining Methods [1½ Questions] : Introduction, Classification, Types of weld and weld joint, Different welding processes, Weld Symbols, Defects in Welds, Testing of welds, Quality Control of welds, Robotic welding, Brazing and Soldering
- Ceramic and Glass Products, Powder Metallurgy [1½ Questions]



References

■ Textbook

- Manufacturing Processes for Engineering Materials - S. Kalpakjian and et. al.
- Metal Cutting: Theory & Practice- A. Bhattacharyya
- Metal Cutting Theory and Cutting Tool Design - Ersinov and others
- Metal Cutting Principles - M. C. Shaw
- Materials and Processes in Manufacturing - E. P. DeGarmo and et. al.
- Manufacturing Processes - M. L. Begeman and et. al.

■ Journals

- CIRP Annals
- JSME International Journal
- Journal of Advanced Manufacturing Technology
- Journal of Material Processing Technology
- ASME
- Wear
- IMechE



Marks Distribution

Total Marks: 300						
Class Test (20%)					Class Attendance (10%)	Final Examination (70%)
1	2	3	4	5		
20	20	20	20	20	10	210

Class Test-1	Metal Casting Processes
Class Test-2	Forging
Class Test-3	Sheet Metal Forming
Class Test-4	Metal Joining Processes
Class Test-5	Ceramic and Glass Products



INTRODUCTION: MANUFACTURING PROCESSES

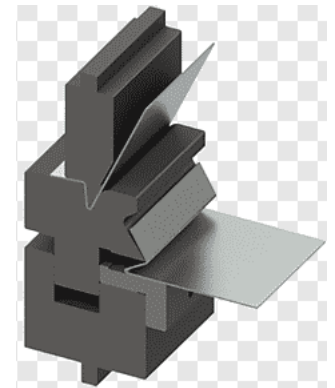
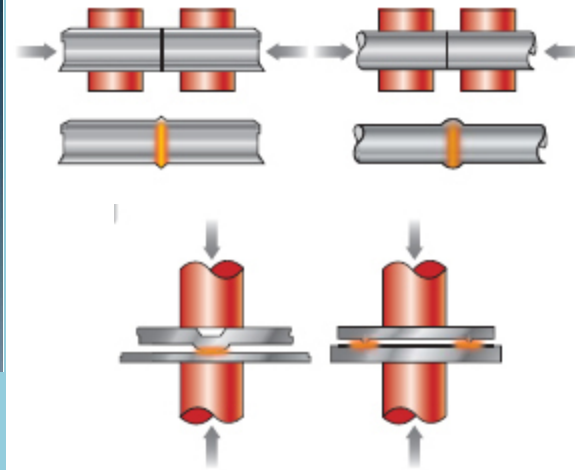
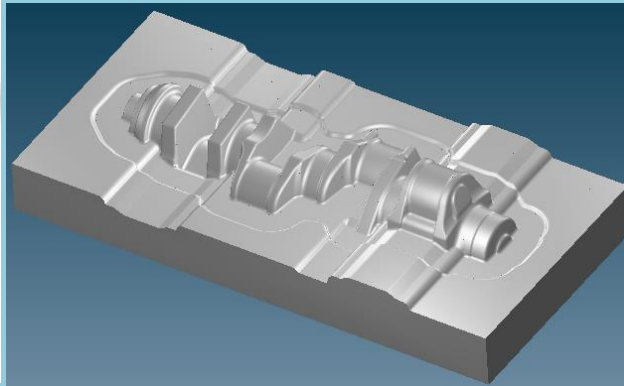
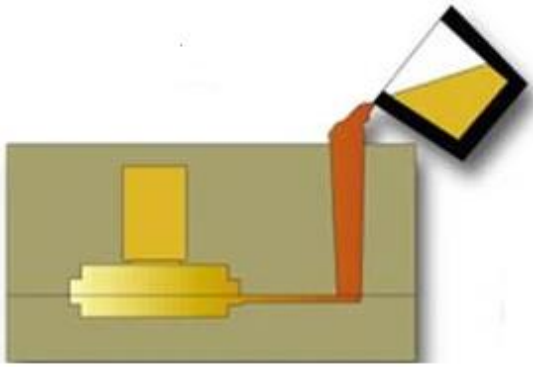

DR. NIKHIL R. DHAR

Professor, IPE Department
BUET

Manufacturing

- Manufacturing is a process for converting ideas and market or customer needs into artifacts; includes **design, procurement, test, finance, human resources, marketing,** etc. **Manufacturing** is the conversion of raw materials into useful products
 - Creating shapes by various means and assembling these shapes into a useful product. A physical product always has a shape
 - Function
 - Aesthetics
 - These shapes are created by a wide variety of processes
- Manufacturing Trends
 - Products must meet specifications, design requirements, and regulatory standards.
 - Product must be economic and environmentally friendly.
 - Quality must be built into the design.
 - Methods must be flexible.
 - Manufacturers must listen to customer feedback.
 - Productivity must be constantly improved.



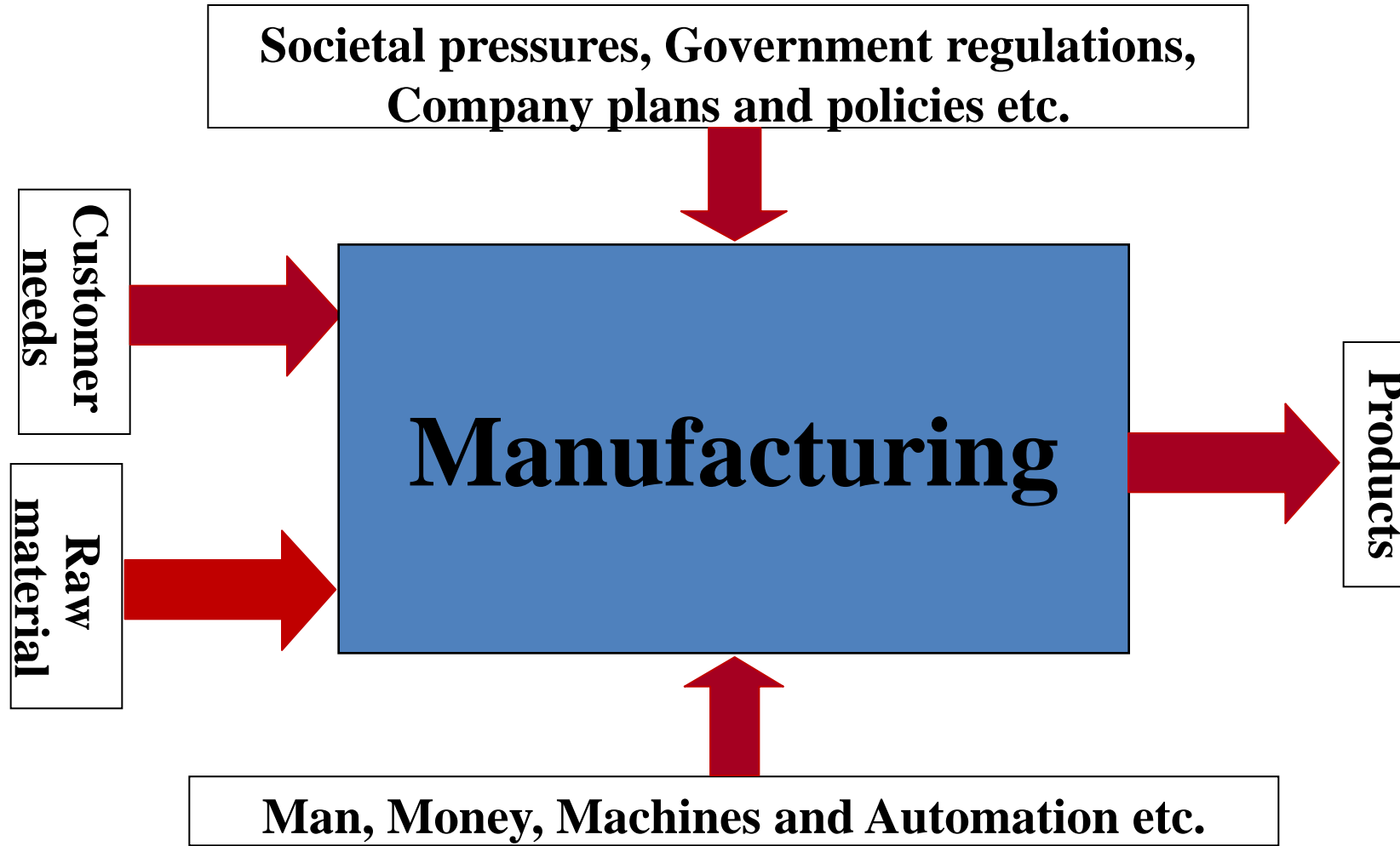

Engineering Materials

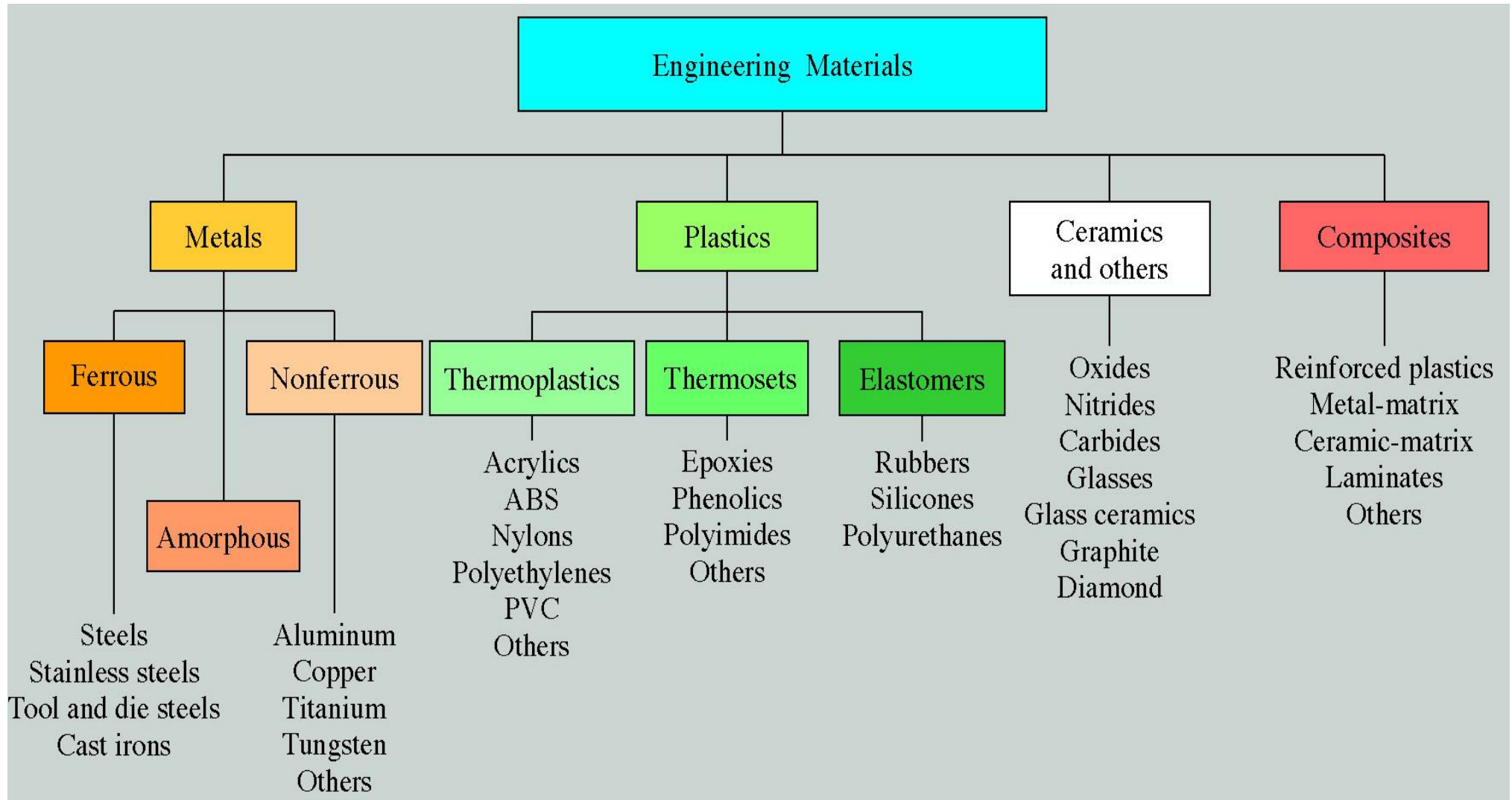

Manufacturing Processes

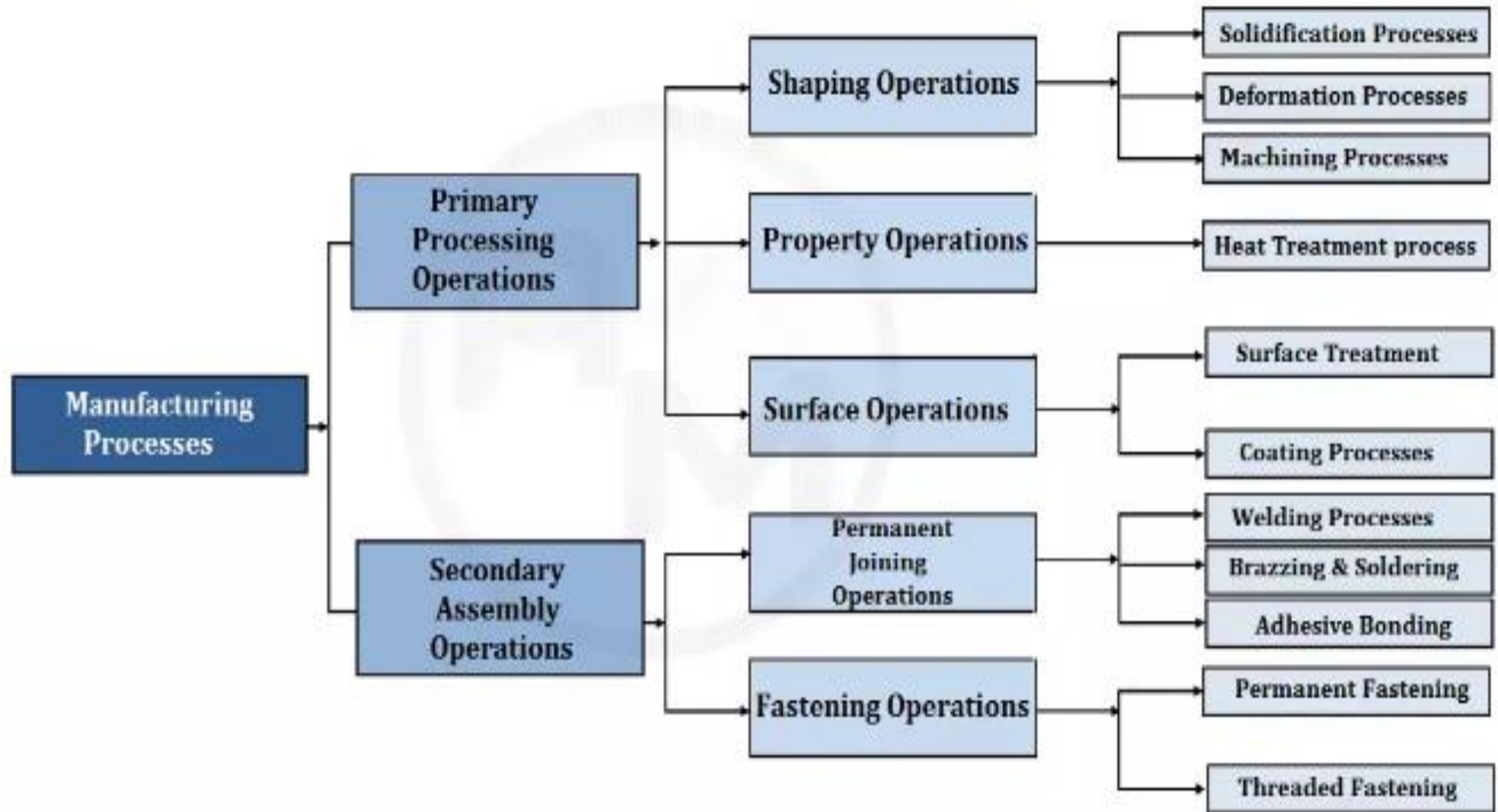

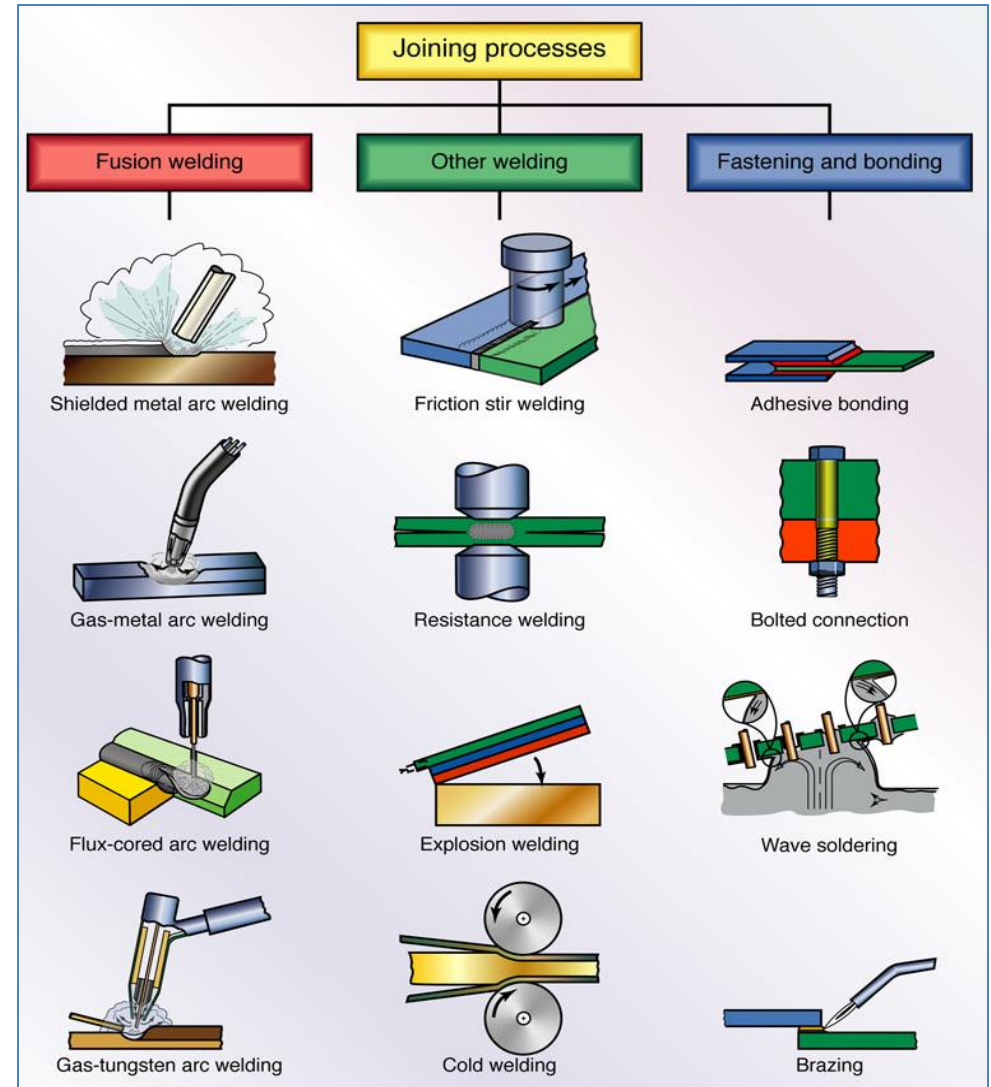
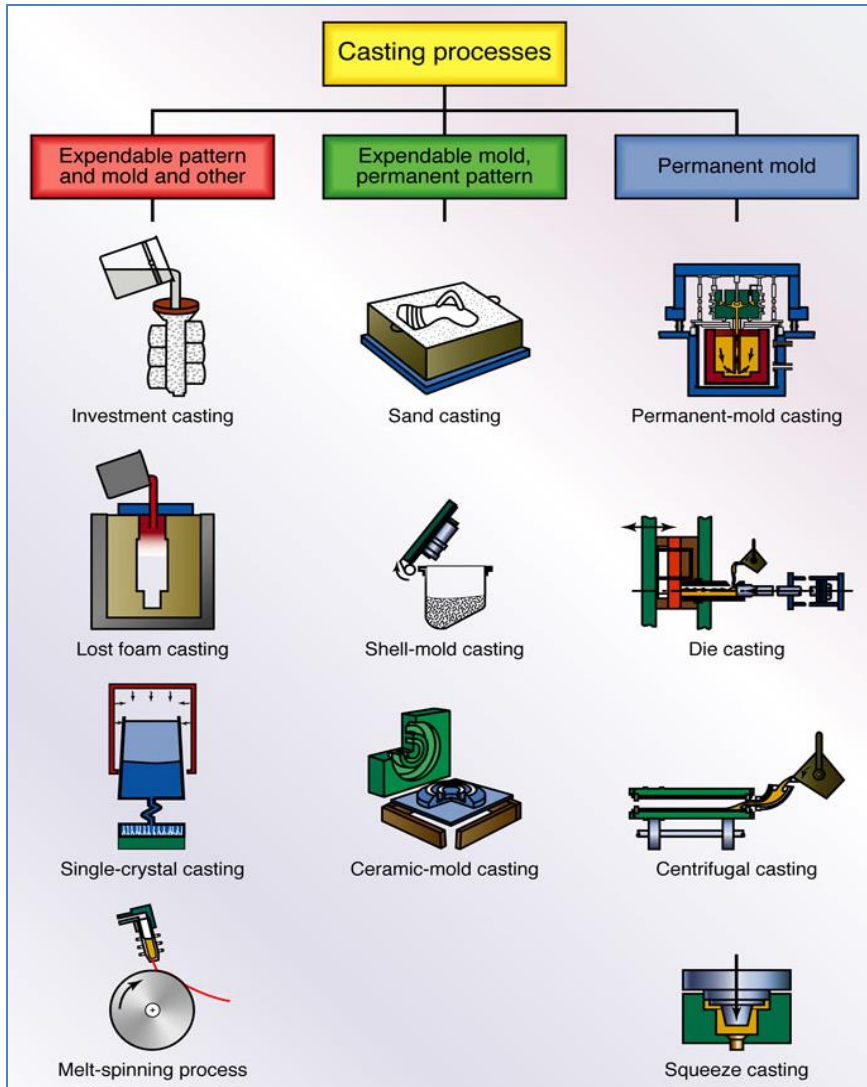

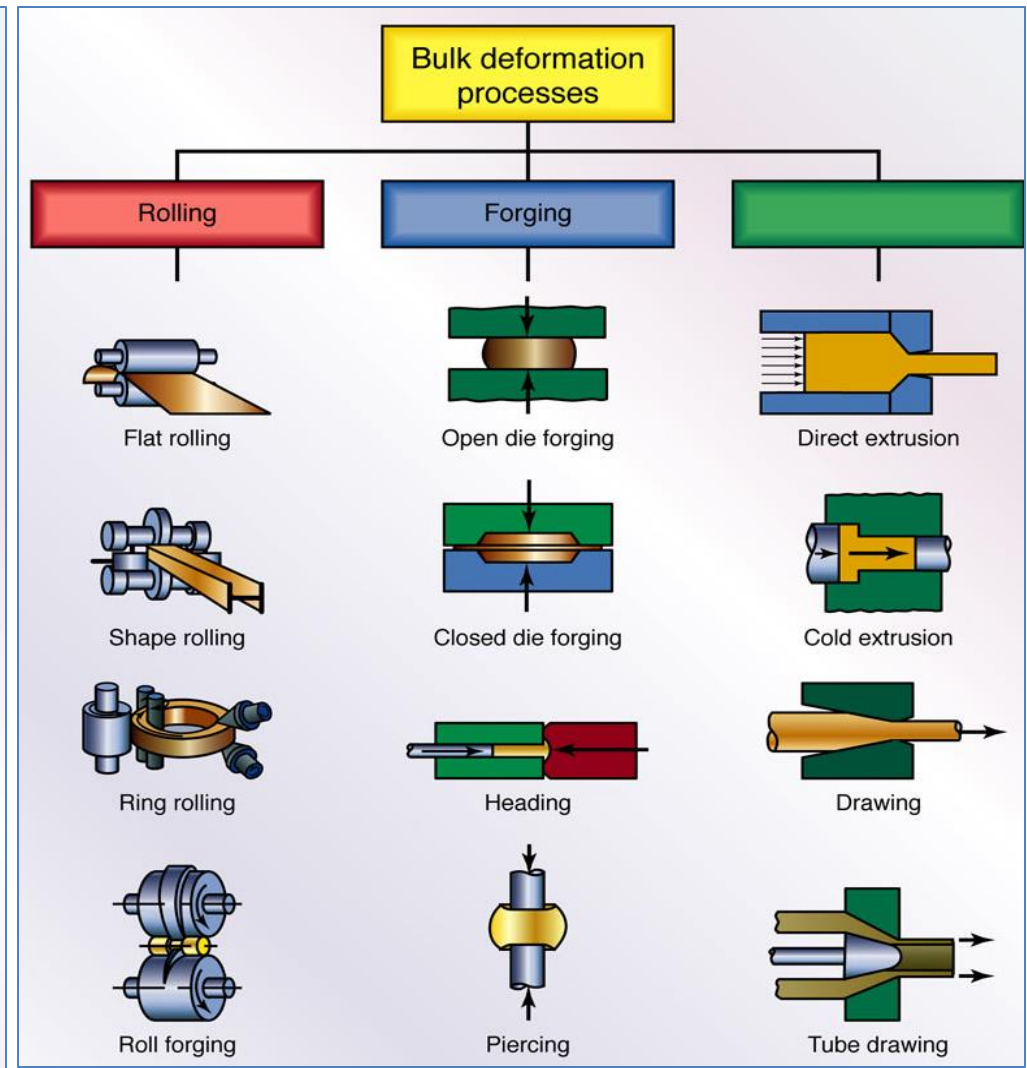
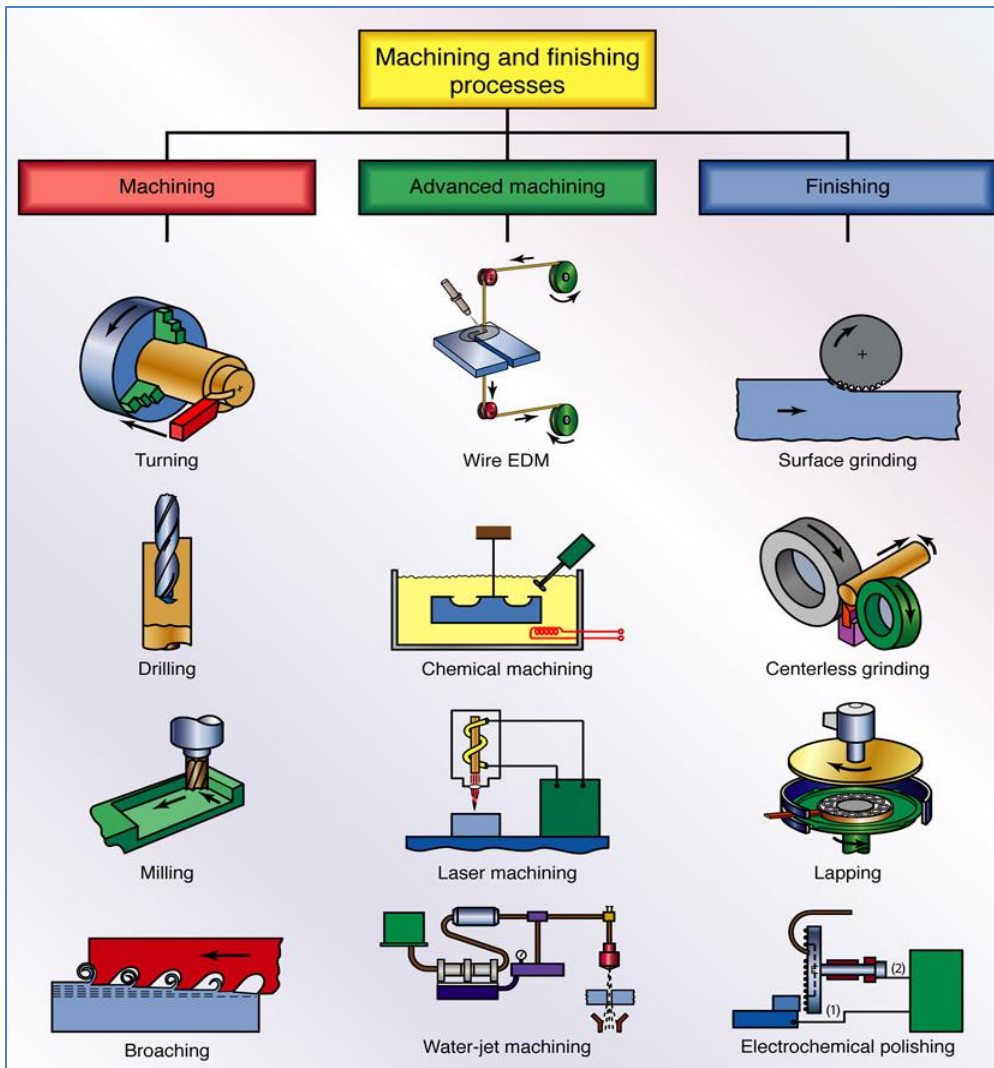

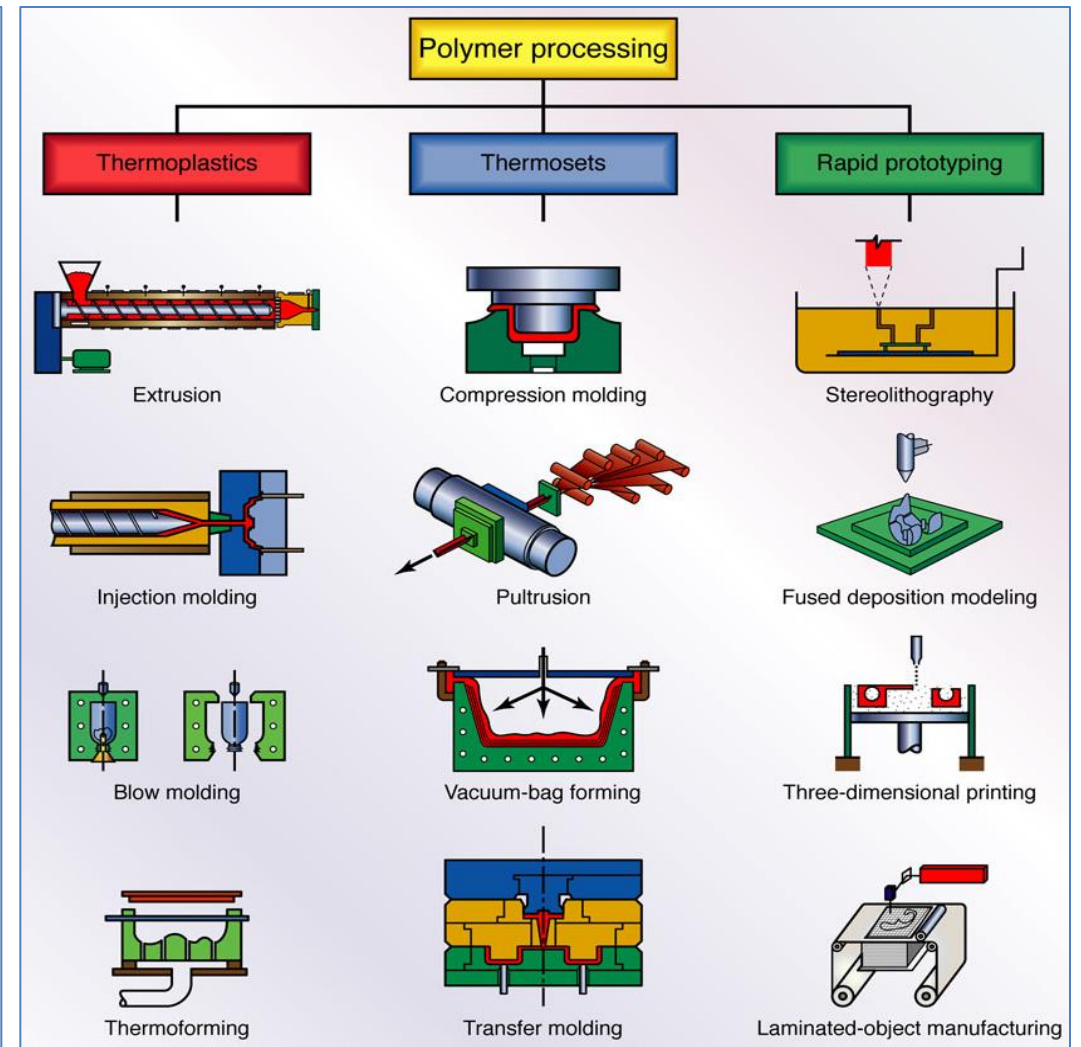
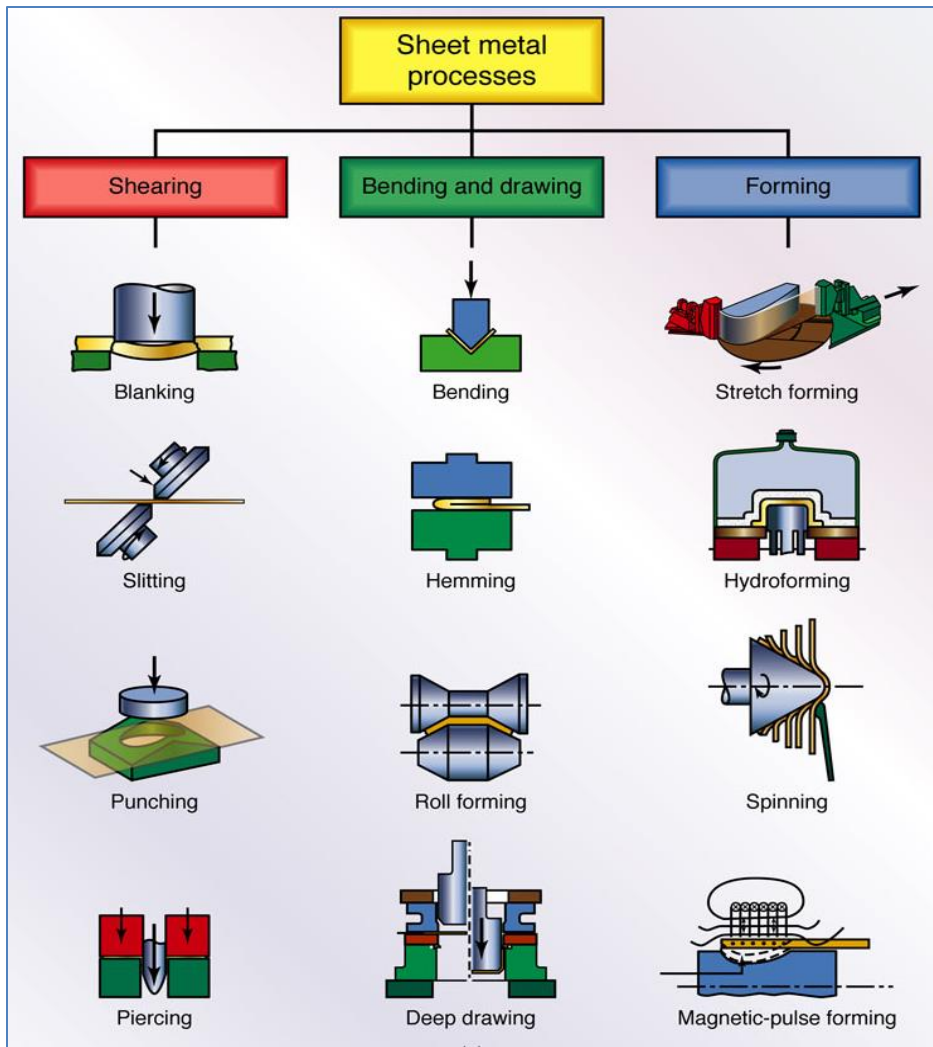

Manufacturing Products

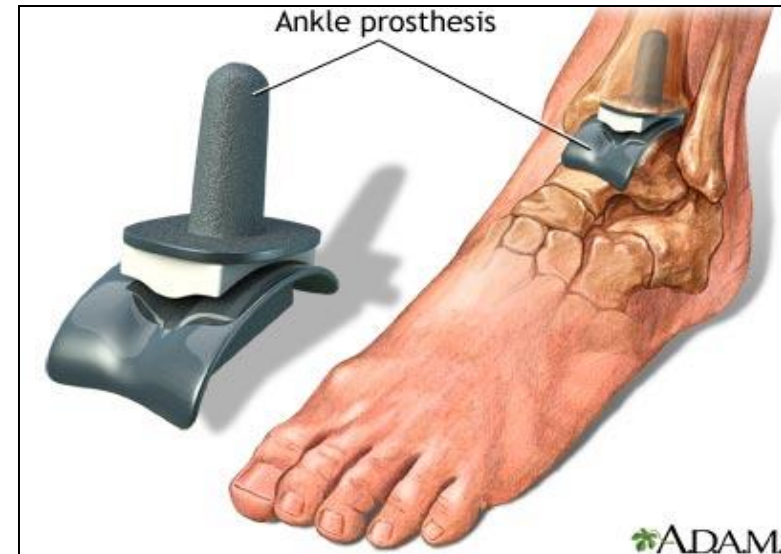

Business and Industry



Computer Equipment



Furniture

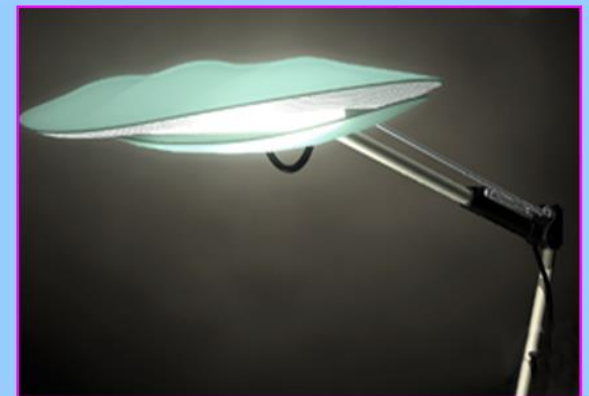

Medical and Scientific

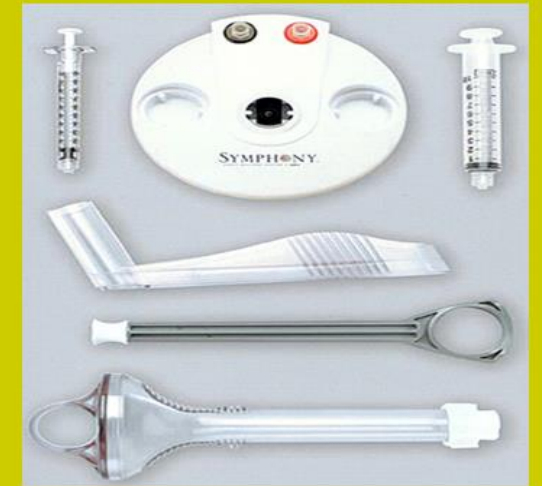
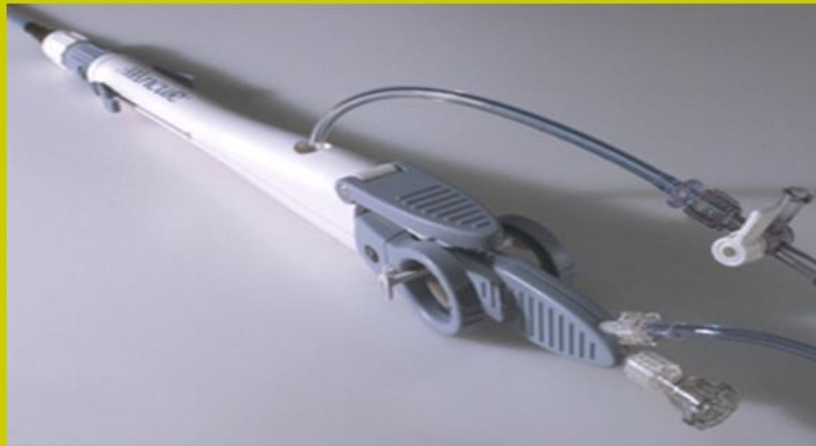

Transportation



Hip Replacement

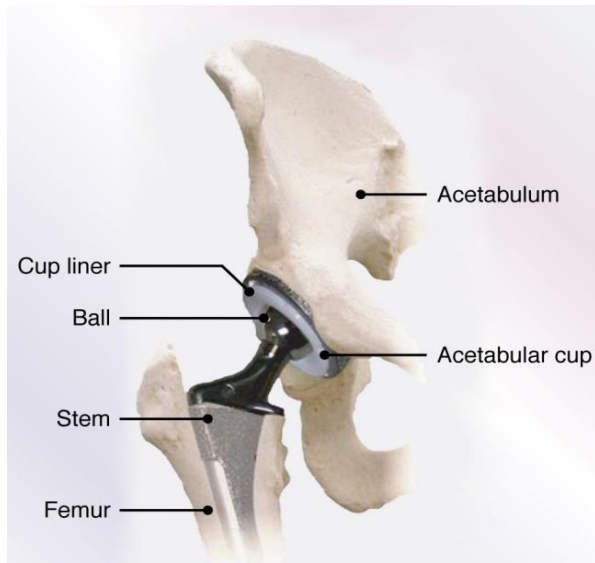

Components of a total hip replacement.

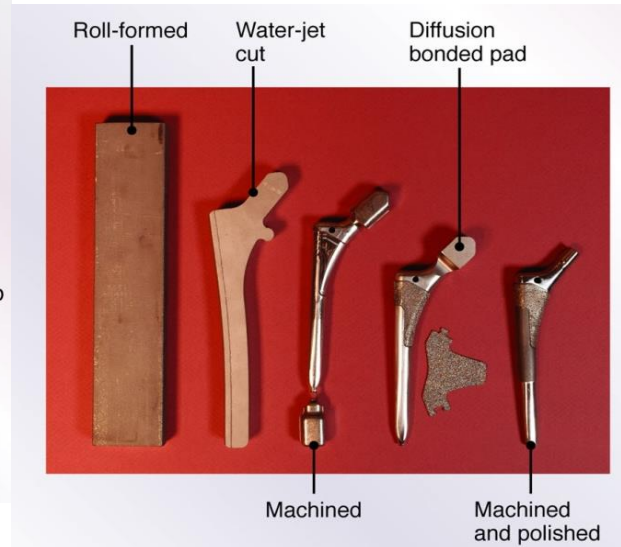

Manufacturing steps in the production of a **roll-formed** and machined total hip replacement stem

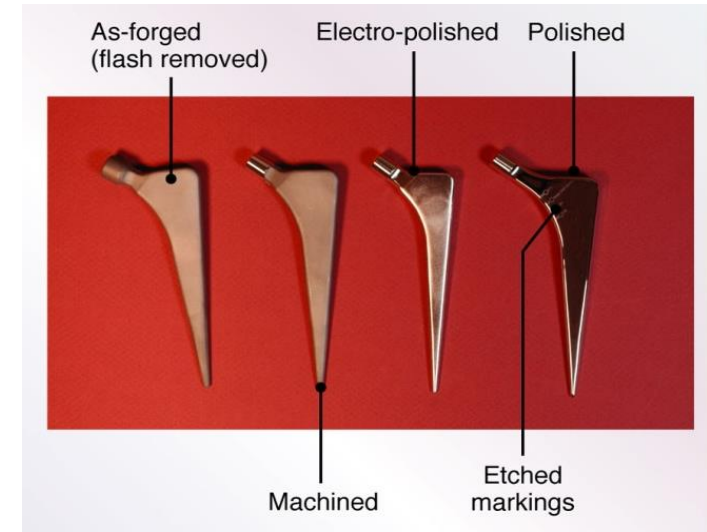

Manufacturing steps in the production of a forged stem. Hip stems can also be produced by **investment casting, metal injection molding, insert injection molding, and assorted other processes.**



CAD/CAM to Make Sunglasses Mold

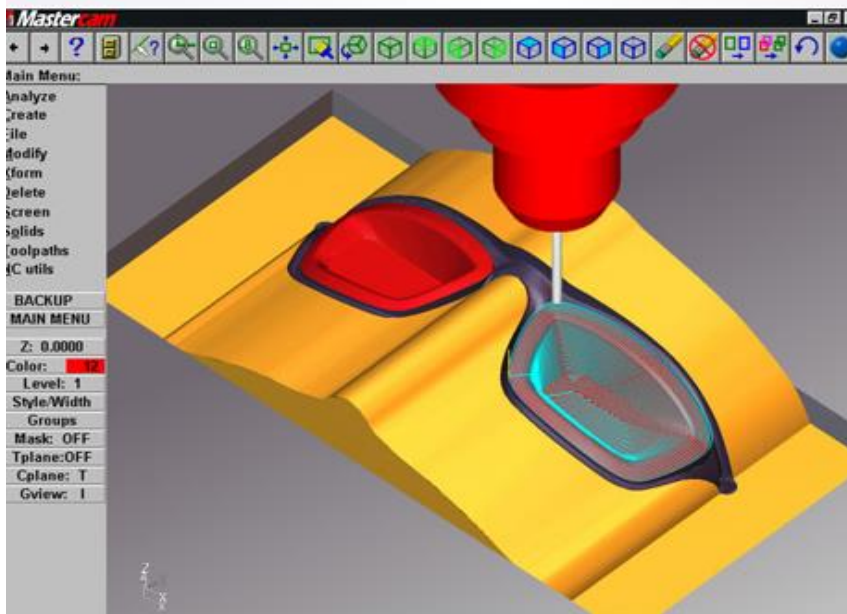

Computer model of the sunglasses as designed and viewed on the monitor.



Machine the die cavity using a CNC milling machine



Final Product

